

Study on Diversion Model of Task Modularity in Complicated Building System Projects

Ying-Chang Yu¹, Tomonari Yashiro², Satoshi Yoshida³ and Zhi Qiu*⁴

¹ Assistant Professor, Department of Architecture, Tamkang University, Taiwan

² Professor, Institute of Industrial Science, The University of Tokyo, Japan

³ Professor, Master Program of Innovation for Design and Engineering, Advanced Institute of Industrial Technology, Japan

⁴ Associate Professor, College of Civil Engineering and Architecture, Zhejiang University, China

Abstract

Design, technology, and management are three key elements that contribute to the success of any building project and are usually dynamic because of variations in players of any particular project. According to previous research, the quantity of tasks or information within the interfaces among players affects the project's probability of success or failure. The task or information diversion and adjustment are sources of such a dynamic phenomenon. Conventional project management and construction design focus on critical path, targets, or cost efficiencies, but these methods do not adequately identify the interface complexity among players because no visualized model is used to demonstrate the dynamic behavior of tasks performed by various players. This study aims to identify the dispersion of design, technology, and management tasks among players using the Task Structure Matrix (TSM) model, and visualize the correlation between task dynamics and project outcomes. A building envelope project, which is the most complex area of a building project, was utilized to demonstrate this model, and this shows that the rearrangement of external dependencies effectively reduces the quantity of interface tasks, leading to project success. The findings also demonstrate the TSM model as an effective observation tool for this purpose.

Keywords: modularity; integration; task dependency; task structure matrix; task diversion

1. Introduction

Because of substantial scientific advancements in design, technology, and management within the field of architecture, nowadays, building projects are sufficiently complex because they may need to be organized by more than one participant. In some cases, the complexity of a modern architecture project is even greater than that of an aircraft project. Professional players are increasingly separated from conventional project players to provide better focus to their tasks. In addition, if a project involves participants from different countries and different backgrounds, the approach to the project can differ depending on the background of each participant, which can cause uncertainty in relation to achieving project goals. Therefore, minimizing this uncertainty is key to the success of a project.

2. Theory and Literature Review

In a report entitled "Study of the Shift of Construction Technology and Organizational Configuration Based on the Development of Architectural Elements" (Yashiro and Yoshida, 2005), the authors noted that participants from different countries showed antagonistic differences in their design methods in relation to modularity and integration. They also observed how different orientations of integration and modularity shape the final outcome of artifacts among different cultures.

In this respect, the task structure matrix (TSM) was introduced in "Design Rules, Vol. 1: The Power of Modularity" (Baldwin and Clark) as a methodology for modularity in response to a dynamic economic and commercial world. Following this, in a study entitled "Comparative Studies on the Regional Differences of Modularity Design Tendency between the United States and Japan" (2014), the author demonstrated the use of the TSM as an effective model for visualizing the task mapping of differentiating construction methods which reflected each players' tendencies. In addition, the findings determined a process of building construction management by reducing the level of dependency among players.

*Contact Author: Zhi Qiu, Associate Professor,
College of Civil Engineering and Architecture, Zhejiang University
No. 866, Yuhangtang Road, Hangzhou City, China
Tel: +86-186-5718-2859
E-mail: qiuzhi0710@yahoo.co.jp

(Received April 5, 2015 ; accepted February 12, 2016)
DOI <http://doi.org/10.3130/jaabe.15.239>

3. Hypothesis and Research Methods

3.1 Definition

In this study, the word "task" is determined as an action element that can be accumulated to provide a service or to form an artifact. It can represent information, execution of a process, or can be a component. Thus, dependency among task elements is the link required to maintain a task function. External dependency is defined as a task that is indispensable to an entire system but exists beyond the scope of each module or players and thus needs to be executed by multiple modules or players. External dependency can therefore be a task linkage between two player modules, and high numbers of external task linkages between two players indicate a stronger mutual need between them to execute a project. An ill-performed external task or error can be a source of failure, and this occurs because of the inability of a player to reach an agreement by absorbing or correcting the error.

Furthermore, in this study, task diversion is defined as a methodology used to reduce the level of external dependency among task modules by rearranging the group of task modules.

3.2 Hypothesis

Construction design is a process that reduces or relocates the external dependency by rearranging player modules.

3.3 Analysis Modeling Methodology

The scientific model, TSM, has been proved to be an effective tool in identifying and visualizing the distribution of project tasks among players; its methodology is provided below.

3.3.1 Task Structure Matrix Based on Dependency Structure Matrix

While designing a nuclear power plant in 1967, Donald V. Steward conceived the dependency structure matrix (DSM), which is also known as the design structure matrix, incidence matrix, or design precedence matrix. DSM was systematically introduced to the public in his 1981 book titled "Systems Analysis and Management: Structure, Strategy and Design." The basic idea of DSM is to break down each element of a target artifact into a list and recreate the dependency network among elements for project analysis. Similarly, the TSM uses operational tasks instead of elements to assess a target construction approach.

3.3.1.1 Basic Principle Involved in Task Structure Matrix

By considering a concrete wall with a door as an example of TSM modeling, a designer collects a systematic set of information such as manufacturing processes, specimen's features, and designer's intention to complete the design process. The first step is to list all affective factors of this target work as parameters during the design process and collect corresponding data associated with each parameter. Necessary tasks affiliated to the target work are listed in Fig.1. and Table 1.

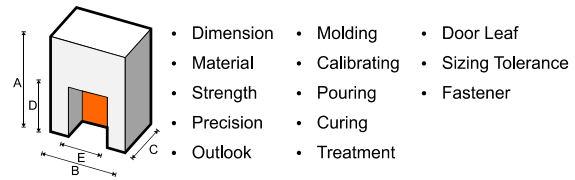

Fig.1. Task List Involved in Making Concrete Block with Door

Table 1. Task Description of Making Concrete Wall with Door

1. The concrete dimension defines the strength of the wall and the size of molding, in addition to the size of the door and installation tolerance.
2. The material used for the block controls its strength and appearance, dictates the method of pouring and the curing time, and also determines the type of fastener used to secure the doorframe.
3. The strength requirement determines the material required for the block, the method used for pouring, the curing time, and also determines the type of fastener connecting the door.
4. The precision requirement defines the appearance of the block and gives guidance for the molding method used and calibration involved in molding, and also affects the door tolerance.
5. The appearance requirement controls the calibration standard and the surface treatment method.
6. The molding method determines the precision of the final product and suitable methods for calibration.
7. The calibrating procedure affects the molding method and determines when the pouring process should start.
8. The pouring process affects the final surface treatment and determines when concrete curing will start.
9. Concrete curing determines when the surface treatment begins and also determines when the door will be installed.
10. Surface treatment as finish of work.
11. The door system defines the type of anchorage fastener required.
12. Size tolerance requires adjustability of the anchorage fastener.
13. Installation of the anchorage fastener determines completion of the work.

The second step in the process is to locate the dependencies among tasks (correlations between each task are listed in Fig.2.). If the completion of lower tasks depends on higher tasks, as shown on the left side of the matrix, this is labeled in the lower left corner, and if the dependency is reversed it is labeled in the upper right corner. Where both types of task are interdependent, they are labeled on both sides.

		1	2	3	4	5	6	7	8	9	10	11	12	13
Group 1	Dimension	1												
	Material		2	X										
	Strength		X		3									
	Precision					4		X						X
	Outlook			X			5							
Group 2	Molding						6	X						X
	Calibrating								7	X				X
	Pouring							X		8				
	Curing								X		9			
	Treatment									X	X	10		
Group 3	Door Leaf											X	11	
	Sizing Tolerance										X			12
	Fastener												X	X

Fig.2. Task Structure Matrix (TSM) for Task

For example, a dependency mark on one side suggests a hierarchical relationship between two tasks, where one dominates the other, and dependency marks on both sides show that two tasks are interdependent.

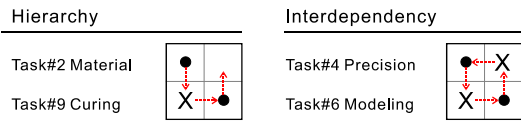

Fig.3. Principle of Task Marking

3.3.2 Basic TSM Module

For demonstration purposes, this research defines three different task groups based on affiliated attributes. For example, the block dimension, material selection, system strength, precision requirement, and outlook requirement in group 1 are design oriented; the molding method, calibrating process, pouring procedure, curing control, and surface treatment in group 2 are fabrication oriented; and the door, sizing tolerance, and anchorage fastener in group 3 are product component oriented.

		1	2	3	4	5	6	7	8	9	10	11	12	13
Group 1	Dimension	1												
	Material		2	X										
	Strength		X	X	3									
	Precision					4		X						X
	Outlook			X			5							
Group 2	Molding		6	X			X		6	X				X
	Calibrating						X	X	X	7				X
	Pouring			X	X						8			
	Curing			X	X							9		
	Treatment					X					X	X	10	
Group 3	Door Leaf											X		11
	Sizing Tolerance			X										12
	Fastener			X	X								X	X

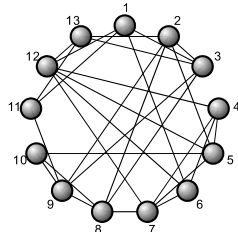

Fig.4. Left: TSM Right: Task Flow Diagram (TFD)

Following a rationalization process using the TSM, the Task Flow Diagram (TFD) can be generated by displaying an equivalent task order arrangement (as shown on the right side of Fig.4.). This represents the prototype of task mapping. The following steps demonstrate the various types of interfaces among players.

3.3.2.1 Segmentation Pattern of Typical Owner Lead Procurement

Using this example, we can easily identify the dynamic relationship among entities. The first pattern, which verifies the applicability of the model, is the typical owner procurement (as shown in Fig.5.).

To demonstrate a typical owner lead procurement, this research divides the TSM into three groups of tasks according to affiliated attributes. The matrix is thus further segmented into nine sub-matrices (3 X 3). The design oriented task, group A, represents the tasks that the architect needs to carry out in a construction project, group B represents the fabrication oriented task to be executed by the contractor, group C represents the task of attaching the door to the concrete block after completion of task group B.

Segmentation creates three pairs of interdependent blocks among task groups in TSM, {A-B}/{B-A}, {A-C}/{C-A}, and {B-C}/{C-B}. In this way, the TFM clearly shows separation of the original TFM from

Fig.4. into three groups, with some of the original connections among groups stretching externally. These exposed dependent task connections represent interface tasks among entities.

		1	2	3	4	5	6	7	8	9	10	11	12	13
Player A	Dimension	1												
	Material		2	X										
	Strength		X	X	3									
	Precision					4		X						X
	Outlook			X			5							
Player B	Molding		6	X			X		6	X				X
	Calibrating						X	X	X	7				X
	Pouring			X	X						8			
	Curing			X	X							9		
	Treatment					X				X	X	10		
Player C	Door Leaf											X		11
	Sizing Tolerance			X										12
	Fastener			X	X								X	X

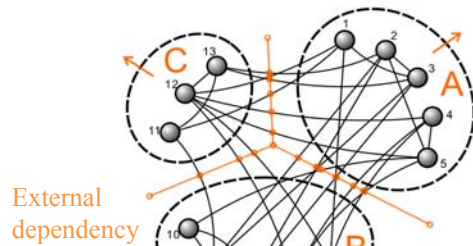

Fig.5. TSM & TFD of Typical Owner Lead Procurement

3.3.2.2 Segmentation Pattern for Typical General Contractor Operation

Following the topological pattern of typical general contractor operation, the architect is in charge of design and thus defines quality requirements; this covers all tasks in the design group (tasks #1~#5). A general contractor awarded the contract then takes full charge and responsibility for the entire construction process, which covers all the tasks determined as belonging to construction (Tasks #6~#13), as shown in Fig.6.

		1	2	3	4	5	6	7	8	9	10	11	12	13
Player A	Dimension	1												
	Material		2	X										
	Strength		X	X	3									
	Precision					4		X						X
	Outlook			X			5							
Player B	Molding		6	X			X		6	X				X
	Calibrating						X	X	X	7				X
	Pouring			X	X						8			
	Curing			X	X							9		
	Treatment					X				X	X	10		
Player C	Door Leaf											X		11
	Sizing Tolerance			X										12
	Fastener			X	X								X	X

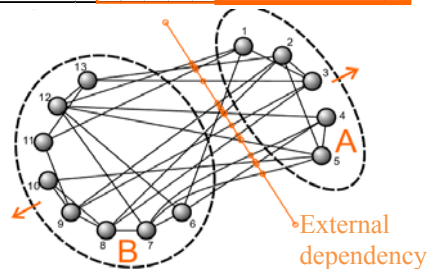

Fig.6. TSM & TFD of Typical General Contractor Operation

If we apply this pattern to the case in Fig.5., the interdependent task connections within matrix blocks $\{B-C\}/\{C-B\}$ are then distributed internally within task module B. The tie between molding calibrating and the door size tolerance is then absorbed as being an inner task for player B. In addition, the interdependent task connections in matrix blocks $\{A-B\}/\{B-A\}$ and $\{A-C\}/\{C-A\}$ are merged and dealt with by both player B and A. For instance, the dependent connection between concrete strength and door anchoring fastener was originally determined as being handled by players A and C and is now handled by players A and B. As a result of these rearrangements, the connections interface in TFM would also be redistributed.

3.3.2.3 Segmentation Pattern of Typical Design-Build Contract

This research also uses design-build contract construction as another topological pattern type that can be used to verify the applicability of the analytical process. In such a case, although the design-build contractor takes complete charge of design and production, due to inherent complexities (or to be cost efficient) the design still requires external outsourcing of products, as shown in Fig.7.

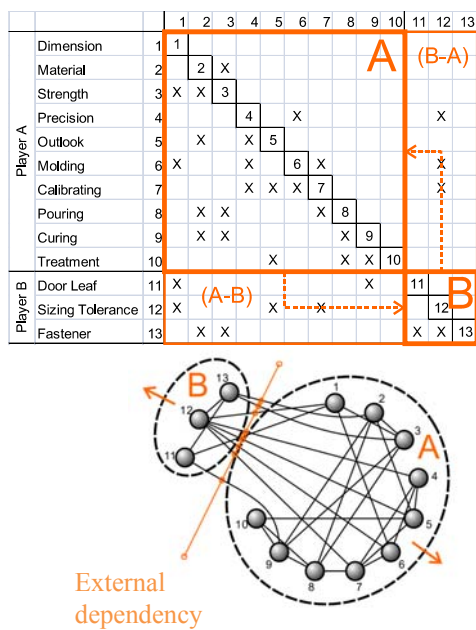

Fig.7. TSM & TFD of Typical Design-Build Contract

Compared to the prototype case in Fig.5., the design-builder is in charge of both the design and construction. In this case study, the design-builder has responsibility of fulfilling design tasks #1~#5 and construction tasks #6~#10, in addition to procuring products from a second party (included in tasks #11~#13).

In such an arrangement, the TSM is sliced between tasks #10 and #11, as this would internalize the original interdependent matrix blocks $\{A-B\}/\{B-A\}$ in Fig.5. as being inner tasks within the scope of the design-builder. For example, the dependent task connection between

outlook requirement and surface treatment is solved internally as an intra-organization task. The additional procurement activity merges the original interdependent matrix blocks $\{A-C\}/\{C-A\}$ and $\{B-C\}/\{C-B\}$ from Fig.5. into $\{A-B\}/\{B-A\}$. In this respect, the dependent task connection between material selection and the anchoring fastener is now under the design-builder's scope, as he/she has inherited the design privilege from the architect's role.

Consequently, the task connection flow across interfaces is redistributed, as shown at the bottom of Fig.7.; this helps the researcher to visualize and identify transitions during contract renegotiation.

3.3.3 Mechanism of Uncertainties Leading to Project Failure

In a previous study, the author observed that each project consists of unique TSM patterns, and that they may also have various alternative modules due to the structure of dynamic player structure. Due to the dynamic nature of task transmission among entities and components, it is also of note that any disconnection in the task flow (failed dependency) on certain critical paths increases the probability of systematic failure in building construction. There are two major patterns of failure that can be observed in the task structure matrices, and these are identified as follows.

3.3.3.1 Chain Reaction of Task Failure

In sequential task patterns, a failed task connection causes a deficiency in achieving the subsequent task, and all further tasks are not performed as planned due to insufficient input, as shown in Fig.8.

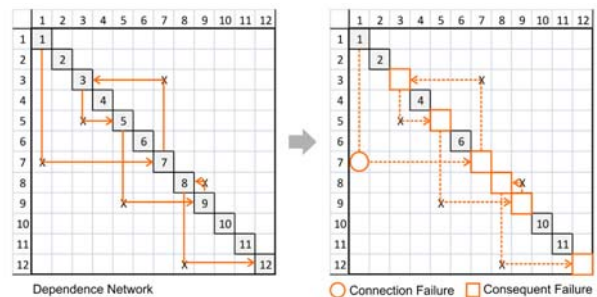

Fig.8. Chain Reaction in TSM

3.3.3.2 Ripple Effect of Task Failure

In typical building construction projects, each task generally has multiple dependencies on other tasks. When one task fails, the effect on a subsequent task group is amplified, and this causes a ripple effect on the whole project, as shown in Fig.9.

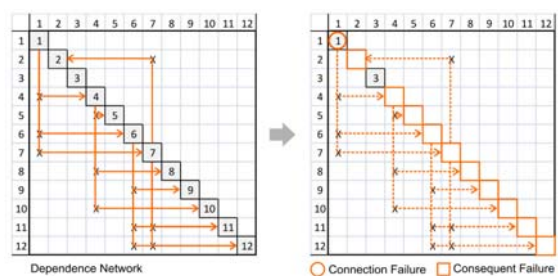

Fig.9. Ripple Effect in TSM

4. Verification using a Real Project

A transnational building envelope project is selected to verify task dependency breakdown leading to construction failure, using a demonstration of how modular design could have improved project success.

4.1 Description of Selected Project

This project was carried out by the developer, Take One, LLC, with Winka Dubbeldam, a native of the Netherlands, as the architect. The project involved converting and renovating an abandoned warehouse into an eleven-story modern loft style condominium on Greenwich Street in lower Manhattan. Most of the existing original building structure was preserved and reinforced, and a newly constructed folding façade was designed to decorate the building's elevation. To meet energy requirements, a specialized angled insulating glass unit was introduced to match the design intention.

As the design architect was not a native of Manhattan, a local architect was required to review building code compliance, and also to sign and seal all documents. A façade consultant, Israel Berger & Associates, was brought in to develop the curtain wall system, and to ensure that a system was used that represented the architect's design intention and also met the owner's budget. In this respect, parallel angled insulating glass was obtained as a unique product from Spain, and the New York based Hong Kong Window Company was awarded the contract for the curtain wall. The organization flow chart for the project is shown in Fig.10.

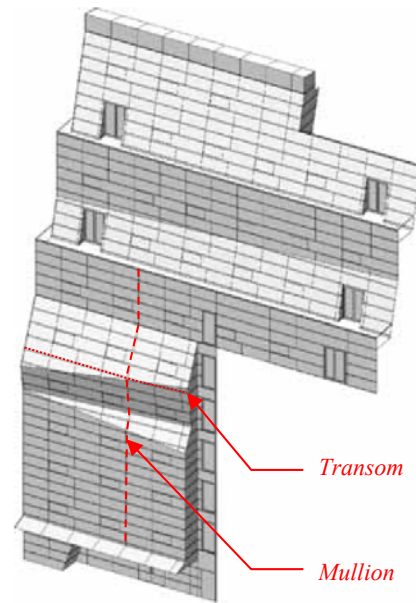

Fig.11. Façade Design of Target Project

The conceptual idea of the design architect involved a façade with a random dynamic surface that was setback to comply with the New York City setback code, as shown in Fig.11. Due to this special design requirement, the architect did not have sufficient experience of the system design, and a professional façade consultant was required. A primitive stick build system was then introduced by the project team, which used six different geometric surface tilting types. The aluminum mullion was designed for assembly of the various angles on-site, and a typical pressure plate method was designed to secure the glass accordingly (details are listed as shown in Fig.12.).

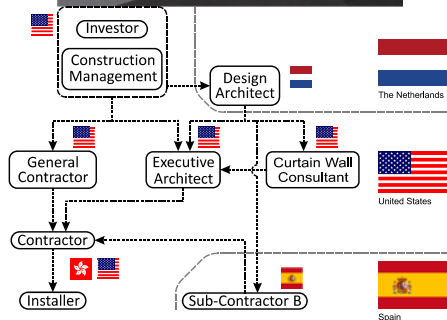
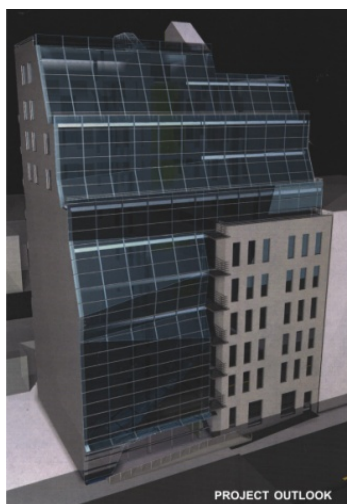

Fig.10. Organization Flow Chart of Project

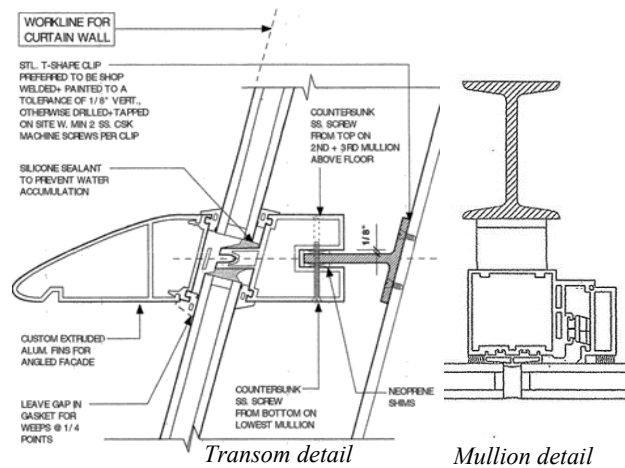

Fig.12. Façade System Detail Presented during Bidding Process

4.2 System Design during Design Development Phase

A stick build system requires less labor during the engineering and design processes, and is suitable for relatively simple projects. However, the geometry of this project was beyond that estimated by the consultant. Thus, three major dependent task connection failures occurred in this project as shown

in Fig.13. Firstly, the geometric design tasks {2-6} fulfilled by the design architect failed to connect with the consultant, and as a result task #6 turned a component design into an inactive task. Consequently, internal tasks #7, 8, 10, 11, 12, & 13 were de-activated, as were the connections to external tasks #18, 24, 25, 26, & 27 (shown by the orange lines in Fig.13.).

Fig.13. Furthermore, Task #13, geometry transition, was neglected by the façade consultant due to an incomplete understanding of the project's geometry, and therefore the external connections to tasks #18, 26, 27, and 32 were broken, as shown by the blue lines in Fig.13. Therefore, due to omission of the three tasks and connections, as shown in the TSM, most

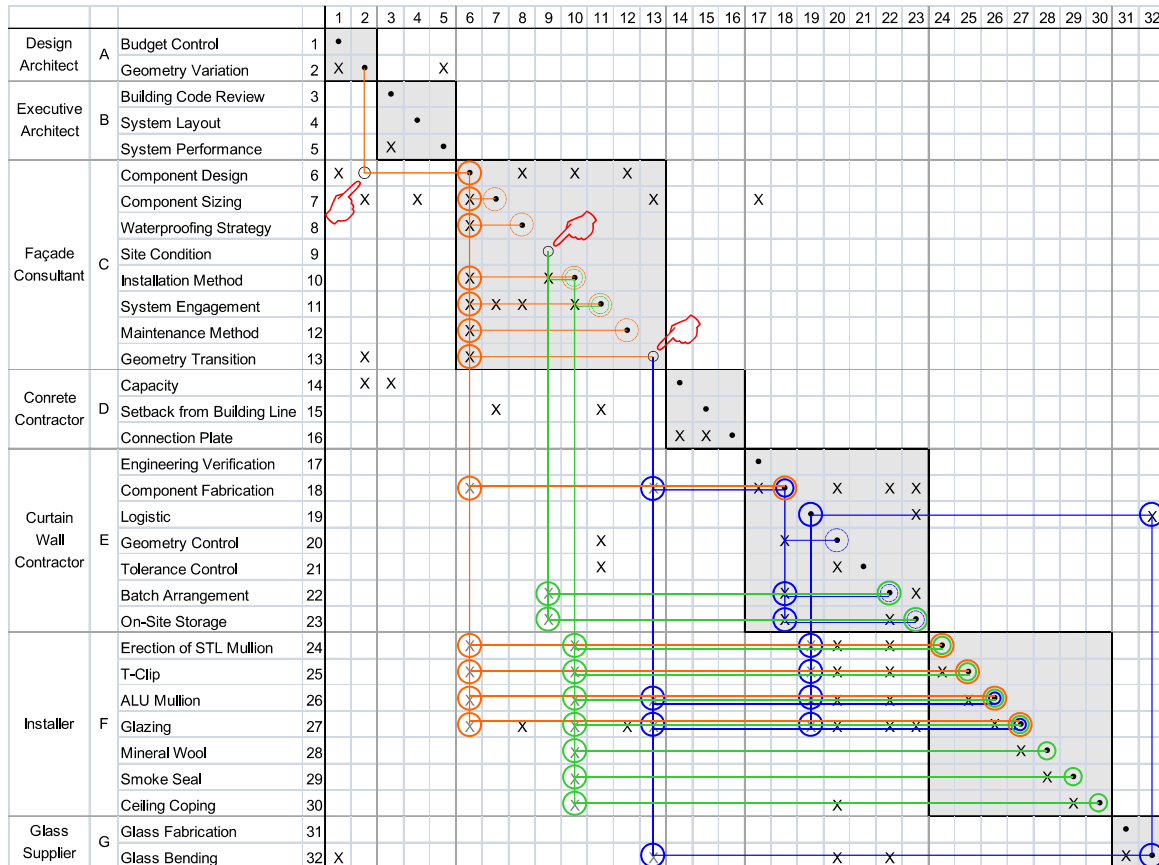

○ System Geometry Design, ○ Onsite-oriented design, ○ Component Geometry Design

Fig.13. TSM of Original Design Approach

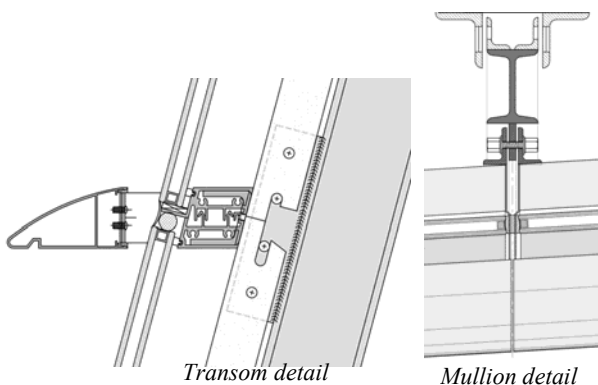

Fig.14. Façade System Detail of Construction

In addition, Task #9, the site condition analysis, was omitted by the consultant. As a result, internal tasks #10 and external connections to tasks #22, 23, 24, 25, 26, 27, 28, 29, & 30 were all deactivated from the design process, as shown by the green lines in

of the subordinating tasks were not given adequate information and became inactive. The project was thus assessed as being too risky to proceed with.

4.3 Improvement during Construction Phase

Taking the information above into account, the design team took a different approach and used a unitized system, which diverted any missing linkages to the contractor, as suggested by contractor (shown in Fig.14.). The contract was then restructured as a design build contract, and the entire system was redesigned by the contractor to ameliorate problems associated with the inadequate information provided by the first party. A unitized system redistributes the task linkages among entities to one single entity. In this respect, most of work is executed in shop, and additional design and coordination is carried out by the contractor awarded the contract.

As the original design was a two-side glazing system without an equalized chamber and drainage system, the

contractor changed the system to that of a structural glazing system, which incorporated aluminum mullions with a stagger-joint profile, as shown in Fig.14. This approach liberated the components from required on-site construction methods, and relocated the production sequence to a controlled environment for precise geometric construction.

In addition, some parts of tasks originally associated with the architect and façade consultant were reassigned to the contractor to consolidate the task information flow, and were internalized into the executive entity. As such, interdependence was largely reduced, as shown in Fig.15.

Task #6 in the original TSM was relabeled as task #9 in the new TSM, which moved it from the vicinity of the consultant to that of the contractor, thus giving the contractor authority to internalize most tasks under their own scope of work by redesigning a unitized system, which was subsequently fabricated in shop, as shown in Fig.17. Geometrical variation, which was the missing task connection between the architect and consultant, was reconnected by redirecting the task into the contractor's scope. In this way, the subordinate task connections #10, 11, 13, 14, 16, 17, 18, 19, 20, 21, 22, & 23 associated with task #9 remained within the player's control.

		R	A	S	D	P	1	2	3	4	5	6	7	8	9	10	11	12	13	14	15	16	17	18	19	20	21	22	23	24	25	26	27	28	29	30	31	32		
Design Architect	A		■		■		1	•																																
					■		2	X	•		X																													
					■		3			•																														
Executive Architect	B	■	■				4			•																														
			■				5			X	•																													
Concrete Contractor	C			■	■		6	X			•																													
					■	■	7					•			X			X																						
					■		8					X	X	•																										
Curtain Wall Contractor	D		■	■	■		9	X	X						•	X	X	X	X	X	X						X													
					■		10	X	X						X	•				X	X																			
				■			11								X	•																								
			■				12								X		•																							
					■		13								X		X	•																						
					■		14								X	X		•						X	X	X														
					■		15											X	•							X														
					■		16	X							X							•																		
			■	■	■		17								X	X								•																
					■		18								X																									
					■		19								X				X	X	•																			
					■		20								X				X		X	•																	X	
			■			■	21								X				X	X	X	X	•	X	X	X														
					■		22		X						X									X	•															
					■		23								X									X	•															
		■			■	24																	X		•	X														
		■			■	25																	X		•	X														
Installer	E				■		26											X							X		X	•												
					■	■	27											X								X		•												
					■	■	28																				X	•												
		■			■	■	29																				X	•												
					■	■	30																					X	•											
Glass Supplier	F		■		■		31																			X											•			
			■		■		32																			X											X	•		

(Task sources: R-Regulation, A-Agreement, S-Specification, D-Drawing, P-Practical Process)

Fig.15. TSM of Actual Construction

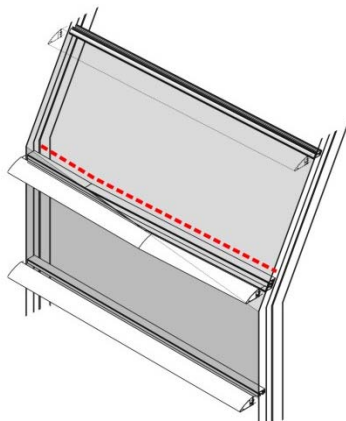

Fig.16. Mullion Composition at Geometry Transition Area



Fig.17. Glazing Process Conducted in Relation to Improved TSM Method

Task #9, the consultant task omitted in the original TSM, was merged into the contractor's tasks as task #12, and the affiliated subordinated task was redirected as an installation method, which then only affected tasks #26 & 27. The neglected task #13, geometry transition, belonging to the façade consultant, was internalized as in-shop production, as shown in Fig.16.

The original design required precise welding of a T-clip, Task #25, to the secondary steel in order to receive the aluminum mullion. However, it was difficult to control welding of the T-clip on-site in relation to the union workers on the field. Therefore, the new design utilized a hook-in system instead of T-clips, as shown in Fig.14. and Fig.18. As a result, the T-clip task was eliminated, and the dependent tasks were reduced accordingly.

From the observation above, a task regrouping process can be addressed as follows. When the system designer, the architect in this case, designs a target work, we can use TSM to analyze the dependency level of such system, and then look for alternative components or configuration, which can decrease or redirect the task dependency to different players in the system, and convert the external dependency into internal dependency. By this method, system dependency level and project risk can be reduced accordingly.

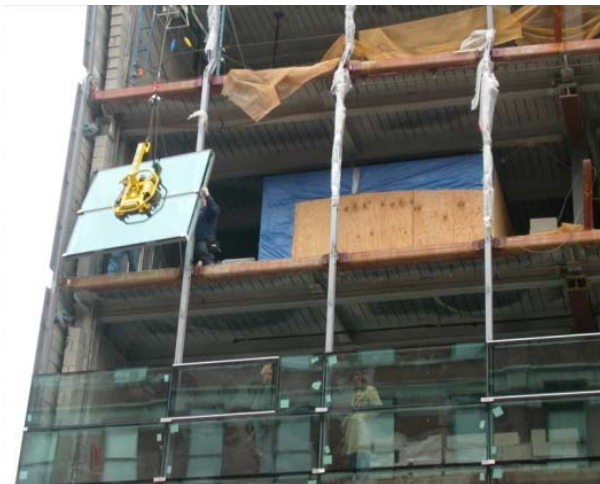

Fig.18. Photo of Construction Progress for Curtain Wall Erection

4.4 Findings from Project Observed

Redistribution of entity liability can serve to streamline design of the construction method. In addition, tasks can be relocated so they fall into the scope of work of skilled participants, thereby mitigating uncertainties stemming from task disconnections. Furthermore, by incorporating a modular construction system design, it is possible to rationalize interdependence among entities. Finally, a major solution to the problems presented in this project is internalization of the task connections.

5. Conclusion

It is evident that project failure patterns are related to the degree of omitted task connections. Various entities that have differing configurations respond to neglected task connections with their own contingency approaches, and result in respectively different outcomes. The use of several alternatives can be considered to minimize the impact of omitted task connections, such as centralized coordination, or rearrangement of a player's liability.

From the observed case study presented in this study, the modular design approach helped to reduce interdependence among components as well as players. It is thus considered that a highly modularized system would allow more players to work together independently, thereby reducing risks, or costs occurring at their interfaces.

References

- 1) Carliss Y. B & Kim B. C, (2000) Design Rules, Vol. 1: The Power of Modularity, The MIT Press.
- 2) Yoshida S, & Yashiro T, (2005) Study on the Concept of "Architecture" to Analyze the Modular Components of Construction Systems, Journal of Architecture and Planning.
- 3) Yoshida S, & Yashiro T, (2005) Study on the Concept of "Architecture" to Describe Design and Construction Systems of Buildings, Journal of Architecture and Planning.
- 4) Yoshida S, & Yashiro T, (2005) Study of the Shift of Construction Technology and Organizational Configuration Based on the Development of Architectural Elements, Journal of Architecture and Planning.
- 5) Lee J & Chun J (2009) Risk Response Analysis Model for Construction Method Using the Forced-Decision Method and Binary Weighting Analysis. Journal of Asian Architecture and Building Engineering, Vol. 8 No. 1. pp.205-212.
- 6) Tsai T. C. & Yang M. L. (2009) Risk Management in the Construction Phase of Building Projects in Taiwan. Journal of Asian Architecture and Building Engineering, Vol. 8 No. 1 pp.143-150.
- 7) Yu Y, Yashiro T, Yoshida S, Qiu Z (2015) Comparative Studies on the Regional Differences of Modularity Design Tendency Between the United States and Japan, Journal of Asian Architecture and Building Engineering, Vol. 14 No. 1, pp.49-56.