

Adaptive Semi-blind Channel Estimation for ST-BC MIMO-CDMA Systems with Hybrid User Signature

Shiunn-Jang Chern and Wang-Chih Huang
Electrical Engineering Department
Tamkang University
Tamsui Dist., New Taipei City, Taiwan, R.O.C
sjchern@mail.tku.edu.tw

Richard Hsin-Hsyong Yang
Department of Computer and Communications
National Kaohsiung First University of Science and
Technology,
Kaohsiung City, Taiwan, R. O. C

Abstract— we extend our previous work to present a new semi-blind transceiver for the direct-sequence code division multiple access (DS-CDMA) system that uses multiple transmit and receive antennas (MIMO) system, equipped with space-time block code (ST-BC). In the transmitter we design a new hybrid augmented user signature (AUS) that composes of the desired user signatures and the prefix/postfix zero-padding sequences with respect to individual transmit-antennas. The hybrid AUS is devised to resolve the phase ambiguity problem which occurs in all blind receivers. At the receiver we propose a Capon-like semi-blind two-branch filter bank receiver, based on the linearly constrained constant modulus (LCCM) criterion, followed by the AUS-assisted semi-blind channel estimation and power method for block symbol recovery. This enables us to partially alleviate the effects of inter-block interference (IBI) and the multiple access interference (MAI). In the ST-BC MIMO-CDMA receiver with two-branch filterbank, we build on the generalized sidelobe canceller (GSC) structure with the RLS for implementing the adaptive semi-blind LCCM receiver. Via intense simulations it reveals that our proposed new transceiver has robust performance against the user's acquisition inaccuracies comparing with current available algorithms and to resolve the phase ambiguity problem.

Keywords—WCDMA; Capon receiver; space-time block code; MIMO; hybrid user signature; zero-padding; GSC-RLS algorithm

I. INTRODUCTION

The direct-sequence code division multiple access (DS-CDMA) system is one of the most promising multiplexing technologies, and has been a core technology used in the wideband CDMA (WCDMA) system for the third generation (3G) wireless communication systems [1]-[4]. By exploiting the spatial diversity of multiple transmit-antennas (T_x) and receive-antennas (R_x) (MIMO), channel capacity of the DS-CDMA systems can be increased effectively to provide wireless broadband services. Also, MIMO systems with the space-time coding (STC) make spatial diversity possible to be exploited in downlink transmission since it relies on multiple transmit-antennas, which is feasible at the base-station [3]-[5]. Among various STC schemes, Alamouti's space-time block code (ST-BC) [5] has a more balanced trade-off between complexity and performance, which is considered to be the most effective STC scheme. The multiple access interference (MAI) is known to be the main performance limitation of the CDMA systems. In addition to the MAI, in the ST-BC MIMO-

CDMA systems self-interference (SI) (due to ST-coding) is also an important issue. It is caused by spatially mixed transmitted signals of the same user, which is induced by multiple transmit antennas in the ST-BC framework.

In the convention pilot-assisted approach a training sequence is often inserted into the data stream for the purpose of channel estimation (CE) in the receiver. Due to the inter-block interference (IBI) and MAI the training-based CE schemes in MIMO systems become quite different. This is because that the required training length per transmit antenna will be proportional to the product of the channel impulse response (CIR) length and the number of transmit-antennas. To achieve spectral efficiency, the blind receiver [9][11] is an alternative candidate, since training sequence is not required with the transmitted signals. However, the conventional blind receivers have inherent phase ambiguity problem [6-8]. Furthermore, for high-bandwidth, high delay-spread channel such as those envisioned for system evolving from the current 3G CDMA standard, a novel type of single-carrier DS-CDMA, named as the cyclic-prefix (CP) CDMA (CP-CDMA) was proposed [12][13], in which the redundant symbols are inserted to mitigate the multipath effect and to simplify the receiver. Inserting sufficient redundant symbols, viz., CP or zero padding (ZP), between consecutive block symbols, has been extensively adopted in the orthogonal frequency division multiplexing (OFDM) systems to combat the effect of IBI in block transmission [14][25]. In this paper, we extend our previous work [10][16] to present a new transceiver framework of the ST-BC MIMO-CDMA system. With specific design of modified hybrid augmented user signature (AUS), and associated with Capon-like channel estimator [9][23] and power method [24] in the receiver, we could resolve the phase ambiguity problem which occurs in all blind receivers. The hybrid AUS composes of the desired user signatures and the modified (prefix/postfix) zero-padding sequences with respect to individual transmit-antenna. Also, low complexity adaptation algorithm using the RLS algorithm under the generalized sidelobe canceller (GSC) structure, named as the GSC-RLS algorithm [15], is derived for adaptively implementing the blind linearly constraint constant modulus (LCCM) [16-22] MIMO-CDMA filter bank of the receiver.

II. NEW TRANSCEIVER FOR ST-BC-MIMO-CDMA WITH LCCM GSC-RLS ALGORITHM

A. Selecting Signal Model Description of Multipath Channel

Let us consider a synchronous downlink K -user ST-BC MIMO-CDMA system with two transmit-antennas and N receive-antennas. Without loss of generality, the first user is assumed to be the desired one, and with the ST-BC scheme two consecutive symbols $b_k(2t-1)$ and $b_k(2t)$ are transmitted for the k^{th} user during two symbol intervals, $2t-1$ and $2t$. Before transmission, the consecutive symbols are spread by the signature code-sequences, \mathbf{c}_{mk} , with length J , where $m = 1$ and 2 are corresponding to two transmit-antennas, respectively. Let us consider the odd time block first, and the new modified prefix/ postfix zero-padding sequences combined with the user signatures, \mathbf{c}_{mk} , of two transmit antennas in the transmitter are exploited to alleviate the effects of ISI and SI under multipath channels. The transmitted signal vectors via the first antenna, which contain the messages of K users at block time t , are expressed, respectively, as [10]

$$\mathbf{s}_1(2t-1) = \sum_{k=1}^K \sqrt{\rho_k} b_k(2t-1) \begin{bmatrix} \mathbf{c}_{1k} \\ \mathbf{0}_{D \times 1} \end{bmatrix} \quad (1a)$$

and

$$\mathbf{s}_1(2t) = \sum_{k=1}^K \sqrt{\rho_k} \left(-b_k^*(2t) \begin{bmatrix} \mathbf{0}_{D \times 1} \\ \mathbf{c}_{1k} \end{bmatrix} + \begin{bmatrix} 1 \\ \mathbf{0}_{(J+D-1) \times 1} \end{bmatrix} \right) \quad (1b)$$

In (1) $\mathbf{s}_1(2t-1)$ and $\mathbf{s}_1(2t)$ are with dimension $(J+D) \times 1$, in which the redundant chip-sequence, named as the zero-padding with block length D , is inserted after/before spreading code sequence, \mathbf{c}_{1k} , of user k to form an AUS vector with dimension $J \times 1$. Specifically, the second term on the right-side of (1b), an extra vector with the first element being unity and zeros, is added. That can be used for instantaneous channel estimation that provides an estimate of initial phase which is required when blind channel estimation is performed. Similarly, in the second transmit-antenna ($Tx2$), we simply insert zero-padding with block length D after/before the spreading code sequence \mathbf{c}_{2k} , of user k to form the augmented signature vectors related to consecutive symbols, and are denoted as

$$\mathbf{s}_2(2t-1) = \sum_{k=1}^K \sqrt{\rho_k} b_k(2t) \begin{bmatrix} \mathbf{c}_{2k} \\ \mathbf{0}_{D \times 1} \end{bmatrix}_{(J+D) \times 1} \quad (2a)$$

and

$$\mathbf{s}_2(2t) = \sum_{k=1}^K \sqrt{\rho_k} b_k^*(2t-1) \begin{bmatrix} \mathbf{0}_{D \times 1} \\ \mathbf{c}_{2k} \end{bmatrix}_{(J+D) \times 1} \quad (2b)$$

In (1) and (2) the average power of the k th user is denoted as ρ_k . We assume that $D \geq L$, where L is the length of channel coefficients and D denotes the length of redundant chip-sequences. Since the AUS vectors with respect to different transmit antennas of the ST-BC MIMO-CDMA system are with different format, thus named as the hybrid AUS scheme. The receiver is synchronized to the first path of desired user, and the delay corresponding to the l th path is denoted as lT_c

where the chip time of spreading code is T_c . If the channel response between the m th transmit-antenna and n th receive-antenna, in a vector form, is denoted by \mathbf{h}_{mn} with dimension $L \times 1$, the composite channel vector is defined as

$$\mathbf{r}_{kmn} = [r_{kmn,1}, \dots, r_{kmn,q}]^T = \mathbf{c}_{mk} * \mathbf{h}_{mn} = \mathbf{C}_{mk} \mathbf{h}_{mn}$$

where the $q \times L$ code matrix \mathbf{C}_{mk} is a circular matrix, with its first column denoting as $[c_{mk1} \dots c_{mkj} \ 0 \dots 0]^T$ and $q = J+L-1$. The convolution of signal vectors, $\mathbf{s}_m(2t-1)$ and $\mathbf{s}_m(2t)$ (for $m=1$ and 2) with the corresponding channel response \mathbf{h}_{mn} are denoted as $\mathbf{P}_{mn}(2t) = \mathbf{s}_m(2t) * \mathbf{h}_{mn}$ and

$\mathbf{P}_{mn}(2t-1) = \mathbf{s}_m(2t-1) * \mathbf{h}_{mn}$, respectively. To facilitate discussion, we define two augmented interference vectors, related to \mathbf{r}_{kmn} , to stand for the effects of ISI, i.e.,

$$\mathbf{r}_{kmn}^{(L)} = [r_{kmn,J+1}, \dots, r_{kmn,q}, \underbrace{0, \dots, 0}_J]_{q \times 1}^T \quad (3a)$$

$$\mathbf{r}_{kmn}^{(R)} = [\underbrace{0, \dots, 0}_J, r_{kmn,1}, \dots, r_{kmn,L-1}]_{q \times 1}^T \quad (3b)$$

In (3) both $\mathbf{r}_{kmn}^{(L)}$ and $\mathbf{r}_{kmn}^{(R)}$ are relating to the previous and next interfering symbols, respectively. At the $2t-1$ time slot, after ST-BC encoder, the received signals vector at n th receive-antenna is given by

$$\begin{aligned} \mathbf{x}_n(2t-1) = & \sum_{k=1}^K \left\{ \sqrt{\rho_k} b_k(2t-1) \begin{bmatrix} \mathbf{r}_{k1n} \\ \mathbf{0}_{D \times 1} \end{bmatrix} - \sqrt{\rho_k} b_k^*(2t-2) \begin{bmatrix} \mathbf{r}_{k1n}^{(L)} \\ \mathbf{0}_{D \times 1} \end{bmatrix} - \sqrt{\rho_k} \begin{bmatrix} \mathbf{0}_{(J+D) \times 1} \\ h_{n,1} \\ \vdots \\ h_{n,L-1} \end{bmatrix} \right. \\ & \left. + \sqrt{\rho_k} b_k(2t) \begin{bmatrix} \mathbf{r}_{k2n} \\ \mathbf{0}_{D \times 1} \end{bmatrix} + \sqrt{\rho_k} b_k^*(2t-3) \begin{bmatrix} \mathbf{r}_{k2n}^{(L)} \\ \mathbf{0}_{D \times 1} \end{bmatrix} \right\} + \mathbf{w}_n(2t-1) \end{aligned} \quad (4)$$

and

$$\begin{aligned} \mathbf{x}_n(2t) = & \sum_{k=1}^K \sqrt{\rho_k} \left\{ -b_k^*(2t-1) \begin{bmatrix} \mathbf{0}_{D \times 1} \\ \mathbf{r}_{k1n} \end{bmatrix} + \begin{bmatrix} h_{n,1} \\ \vdots \\ h_{n,L} \\ \mathbf{0}_{(J+D-1) \times 1} \end{bmatrix} + b_k(2t+1) \begin{bmatrix} \mathbf{0}_{D \times 1} \\ \mathbf{r}_{k1n}^{(R)} \end{bmatrix} \right. \\ & \left. + b_k^*(2t-1) \begin{bmatrix} \mathbf{0}_{D \times 1} \\ \mathbf{r}_{k2n} \end{bmatrix}_{(q+D) \times 1} + b_k(2t+2) \begin{bmatrix} \mathbf{0}_{D \times 1} \\ \mathbf{r}_{k2n}^{(R)} \end{bmatrix} \right\} + \mathbf{w}_n(2t) \end{aligned} \quad (5)$$

Both noise vectors $\mathbf{w}_n(2t-1)$ and $\mathbf{w}_n(2t)$ are with the same dimension as the received signal vectors. Next, it is of interest to discuss how our proposed scheme can be used to partially remove the effects of ISI and SI. We note that in (4) it has five terms inside the bracket, and except the third term (it contains the information of channel coefficients) and the noise vector, the last D samples of $\mathbf{x}_n(2t-1)$ are nulls. Similarly, in (5) except the second term inside the bracket and noise vector, the first D samples of all other terms contained in $\mathbf{x}_n(2t)$ are nulls. Hence the first L ($L=D$) elements of the second term of (5) contains the information of channel coefficients \mathbf{h}_{1n} which can be easily extracted from the received signals.

Similarly as in even block time index, an extra vector with the first element being unity and zeros defined in $\mathbf{s}_1(2t)$ of (1b) is now removed and added to $\mathbf{s}_2(2t)$ of (2b). With the similar procedure described for extracting channel coefficients \mathbf{h}_1 , we can extract the information of channel coefficients \mathbf{h}_{2n} . After extracting both information of \mathbf{h}_1 and \mathbf{h}_{2n} , by removing the redundancy from the received signal vector, i.e., the last/first D samples of the received signal vector $\mathbf{x}_n(2t-1)/\mathbf{x}_n(2t)$, we can follow the similar approach of [10][16] to design the filterbank receiver to enhance the system performance by depressing the effects of MAI, ISI and SI. Consequently, we obtain the reduced received signal vectors at R_{xn} :

$$\mathbf{x}'_n(2t-1) = \sum_{k=1}^K \sqrt{\rho_k} \{ b_k(2t-1)\mathbf{r}_{k1n} - b_k^*(2t-2)\mathbf{r}_{k1n}^{(L)} \} + b_k(2t)\mathbf{r}_{k2n} + b_k^*(2t-3)\mathbf{r}_{k2n}^{(L)} \} + \mathbf{w}'_n(2t-1) \quad (6)$$

and

$$\mathbf{x}'_n(2t) = \sum_{k=1}^K \{ -\sqrt{\rho_k} b_k^*(2t)\mathbf{r}_{k1n} + \sqrt{\rho_k} b_k(2t+1)\mathbf{r}_{k1n}^{(R)} \} + \sqrt{\rho_k} b_k^*(2t-1)\mathbf{r}_{k2n} + \sqrt{\rho_k} b_k(2t+2)\mathbf{r}_{k2n}^{(R)} \} + \mathbf{w}'_n(2t) \quad (7)$$

Both $\mathbf{w}'_n(2t-1)$ and $\mathbf{w}'_n(2t)$ are the reduced noise vectors with dimension same as $\mathbf{x}'_n(2t-1)$ and $\mathbf{x}'_n(2t)$. By stacking the received signal vectors $\mathbf{x}'_n(2t-1)$ and $\mathbf{x}'_n(2t)$, we form a $2q \times 1$ received vector $\mathbf{y}_n(t)$, with respect to the desired symbols $b_k(2t-1)$ and $b_k(2t)$ i.e.,

$$\mathbf{y}_n(t) = \begin{bmatrix} \mathbf{x}'_n(2t-1) \\ \mathbf{x}'_n(2t) \end{bmatrix}_{2q \times 1} = \sum_{k=1}^K \sqrt{\rho_k} [b_k(2t-1)\mathbf{g}_{nk} + b_k(2t)\bar{\mathbf{g}}_{nk}] + \text{ISI} + \mathbf{v}_n(t) \quad (8)$$

$$= \sqrt{\rho_1} [b_1(2t-1)\mathbf{g}_{n1} + b_1(2t)\bar{\mathbf{g}}_{n1}] + \text{ISI} + \text{MAI} + \mathbf{v}_n(t)$$

where $\mathbf{v}_n = [\mathbf{w}'_n(2t-1), \mathbf{w}'_n(2t)]^T$ is the corresponding noise vector. Similarly, we may define the following parameters as:

$$\mathbf{h}_n = [\mathbf{h}_{1n}^T, \mathbf{h}_{2n}^T]^T, \quad \mathbf{g}_{nk} = [\mathbf{r}_{k1n}^T, \mathbf{r}_{k2n}^T]^T = \Delta_k \mathbf{h}_n,$$

$$\Delta_k = \begin{bmatrix} \mathbf{C}_{1k} & \mathbf{0} \\ \mathbf{0} & \mathbf{C}_{2k} \end{bmatrix}, \quad \bar{\mathbf{g}}_{nk} = [\mathbf{r}_{k2n}^T, -\mathbf{r}_{k1n}^T]^T = \bar{\Delta}_k \mathbf{h}_n^*, \quad \text{and}$$

$$\bar{\Delta}_k = \begin{bmatrix} \mathbf{0} & \mathbf{C}_{2k} \\ -\mathbf{C}_{1k} & \mathbf{0} \end{bmatrix}.$$

Finally, by stacking the outputs from all receive-antennas, we obtain the received vector $\mathbf{y}(t) = [\mathbf{y}_1^T(t), \mathbf{y}_2^T(t), \dots, \mathbf{y}_N^T(t)]^T$, which is the input to the multi-user detector. Similarly, we denote the corresponding stacked vectors as

$$\mathbf{v}(t) = [\mathbf{v}_1^T(t), \mathbf{v}_2^T(t), \dots, \mathbf{v}_N^T(t)]^T, \quad \mathbf{h}(t) = [\mathbf{h}_1^T(t), \mathbf{h}_2^T(t), \dots, \mathbf{h}_N^T(t)]^T$$

$$\mathbf{g}_k(t) = [\mathbf{g}_{1k}^T(t), \mathbf{g}_{2k}^T(t), \dots, \mathbf{g}_{Nk}^T(t)]^T = \mathbf{D}_k \mathbf{h}(t),$$

$$\bar{\mathbf{g}}_k(t) = [\bar{\mathbf{g}}_{1k}^T(t), \bar{\mathbf{g}}_{2k}^T(t), \dots, \bar{\mathbf{g}}_{Nk}^T(t)]^T = \bar{\mathbf{D}}_k \mathbf{h}^*(t)$$

where $\mathbf{D}_k = \mathbf{I}_N \otimes \Delta_k$ and $\bar{\mathbf{D}}_k = \mathbf{I}_N \otimes \bar{\Delta}_k$. With the above definition,

$\mathbf{y}(t)$ can be written as

$$\mathbf{y}(t) = \sqrt{\rho_1} [b_1(2t-1)\mathbf{g}_1 + b_1(2t)\bar{\mathbf{g}}_1] + \boldsymbol{\gamma}(t) \quad (9)$$

The terms in the bracket on the right-hand side of (9) are the desired signals, and $\boldsymbol{\gamma}(t)$ consist of the terms, MAI, ISI, and noise vector $\mathbf{v}(t)$. Now, based on the above formulation, following the approach as in [9][10] the problem becomes to design a two-branch linear filter $\mathbf{F} = [\mathbf{f}(t), \bar{\mathbf{f}}(t)]$ operating on the received vector $\mathbf{y}(t)$ to yield $\mathbf{z}_1(t) = \mathbf{F}^H \mathbf{y}(t)$, an estimate of $\mathbf{b}_1(t) = [b_1(2t-1), b_1(2t)]^T$. Both weight vectors $\mathbf{f}(t)$ and $\bar{\mathbf{f}}(t)$ of the filter bank are obtained by minimizing the filtered output power, subject to the unit-gain constraints with respect to the code matrices of the desired user, followed by the blind Capon channel estimator associated with our proposed hybrid augmented signature code chip-sequences.

B. MIMO CM-GSC-RLS Algorithm with Capon Channel Estimation

As in [8][9], in our design, two branches of linear filterbank can operate, separately, thus we can compute tap weights of the two branches, independently. In what follows, only the derivation of the first branch is given, since with the similar approach the results can be inferred for the second branch. Next, with CM approach, output of the multi-user detector is assumed to be with constant envelop (related to α), which is a common characteristic of the transmitted symbols. The cost functions in the weighted least square (LS) form is defined as

$$J_{CM1}(\mathbf{f}(t)) = \sum_{i=1}^t \lambda^{t-i} \left| \alpha - \mathbf{f}^H(t) \mathbf{y}(i) \right|^2 \quad (10)$$

where λ is the forget factor and t is the number of iteration. The tap weights of $\mathbf{f}(t)$ in the receiver are obtained by minimizing (10) subjects to the constrain, $\mathbf{f}^H(t) \hat{\mathbf{g}}_1(t) = 1$, where $\hat{\mathbf{g}}_1(t)$ is the estimates of $\mathbf{g}_1(t)$ at iteration t . By substituting $\hat{\mathbf{g}}_1(t) = \mathbf{D}_1 \hat{\mathbf{h}}(t)$ back into the constraint, and after some mathematical manipulation we have $\hat{\mathbf{h}}^H(t) \mathbf{D}_1^H \mathbf{f}(t) = 1$, where $\hat{\mathbf{h}}(t)$ an estimate of $\mathbf{h}(t)$. Assume that $\hat{\mathbf{h}}(t)$ is with unit-norm, the constraint becomes $\mathbf{D}_1^H \mathbf{f}(t) = \hat{\mathbf{h}}(t)$, where \mathbf{D}_1 is named as the code-constraint matrix. Eq. (10) can be reformulated as

$$\text{Minimize } J_{CM1}(\mathbf{f}(t)) \text{ subject to } \mathbf{D}_1^H \mathbf{f}(t) = \hat{\mathbf{h}}(t) \quad (11)$$

For simplicity, the framework of GSC is adopted for achieving better numerical stability and lower computational complexity. With the GSC structure the adaptive CM-GSC-RLS algorithm for ST-BC MIMO-CDMA receiver is derived [10]. With the GSC structure, the original tap weights, which satisfy the constraint, can be decomposed into $\mathbf{f}(t) = \mathbf{f}_c(t) - \mathbf{B}\mathbf{f}_a(t)$ [15], where $\mathbf{f}_c(t) = \mathbf{D}_1(\mathbf{D}_1^H \mathbf{D}_1)^{-1} \hat{\mathbf{h}}(t)$ is the part which satisfies the

constraint and independent of data. The remaining part $-\mathbf{B}\mathbf{f}_a(t)$, which is uncorrelated with the constraint, can be viewed as our degree of freedom and can be adapted to suppress the overall interference $\gamma(t)$. The blocking matrix \mathbf{B} is chosen such that $\mathbf{D}_1^H \mathbf{B} = \mathbf{0}$. With above discussion, for the first branch of filterbank, the unconstrained optimization problem now becomes to minimize the cost function with respect to $\mathbf{f}_a(t)$. By expanding $J_{CM1}(\mathbf{f}(t))$, we have [10]

$$J_{CM1}(\mathbf{f}(t)) = \sum_{i=1}^t \lambda^{t-i} \left| \alpha - \left| \mathbf{f}^H(t) \mathbf{y}(i) \right|^2 \right|^2 \cong \sum_{i=1}^t \lambda^{t-i} \left| \alpha - \mathbf{f}^H(t) \tilde{\mathbf{y}}(i) \right|^2 \quad (12)$$

where $\mathbf{f}^H(t) \mathbf{y}(i)$ is the output of first branch of the adaptive filterbank. The intermediate vector for the first branch is defined as $\tilde{\mathbf{y}}(i) = \mathbf{y}(i) \mathbf{y}^H(i) \mathbf{f}(i)$. The optimal solution of $\mathbf{f}_a(t)$ can be solved, by minimizing (12) with respect to $\mathbf{f}_a(t)$:

$$\mathbf{f}_{a,CM}(t) = \mathbf{R}_B^{-1}(t) \mathbf{B}^H \left(\mathbf{R}(t) \mathbf{f}_{c,CM}(t) - \boldsymbol{\theta}(t) \right) \quad (13)$$

Where the correlation matrix and cross-correlation vector are defined as $\mathbf{R}(t) = \sum_{i=1}^t \lambda^{t-i} \tilde{\mathbf{y}}(i) \tilde{\mathbf{y}}^H(i) = \lambda \mathbf{R}(t-1) + \tilde{\mathbf{y}}(t) \tilde{\mathbf{y}}^H(t)$ and

$$\boldsymbol{\theta}(t) = \sum_{i=1}^t \lambda^{t-i} \alpha \tilde{\mathbf{y}}(i) = \lambda \boldsymbol{\theta}(t-1) + \alpha \tilde{\mathbf{y}}(t), \text{ respectively. Also, the}$$

constrained weight vector is denoted as $\mathbf{f}_{c,CM}(t) = \mathbf{D}_1 (\mathbf{D}_1^H \mathbf{D}_1)^{-1} \hat{\mathbf{h}}(t)$, and blocking correlation matrix is $\mathbf{R}_B(t) = \mathbf{B}^H \mathbf{R}(t) \mathbf{B}$. After some mathematical manipulation, we obtain the recursive form of $\mathbf{f}_{a,CM}(t)$:

$$\mathbf{f}_{a,CM}(t) = \mathbf{f}_{a,CM}(t-1) - \mathbf{k}_B(t) e^*(t|t-1) + \Gamma(t) \mathbf{f}_c(t) \quad (14)$$

The summary of GSC-RLS algorithm is listed in Table 1 of [16]. Finally, we can form the complete weight vector $\mathbf{f}_{CM}(t)$. Similar results can be inferred for the second branch. After suppressing the overall interference, the Capon channel estimation is accomplished by maximizing the filter output power. Joined together with the power method [24] we can iterative search the final channel vector $\hat{\mathbf{h}}(t)$. Similar results can be inferred for the second branch. Note that in Table I we give a method of selecting α to improve the performance of the LCCM approach in fading channels.

III. COMPUTER SIMULATIONS

In the following simulations, we consider a 10-user downlink CDMA system which is equipped with two transmit-antennas and $N=2$ receive-antennas, and QPSK modulation is adopted. Gold codes with length 31 and unit-energy are used. The noise coefficients are randomly generated from a complex-Gaussian distribution with zero-mean. The variances of noise coefficients are determined according to SNR, and is defined as E_s / N_0 , where E_s is energy per symbol and N_0 is the power spectral density of noise. The forgetting factor λ is set to be 0.998. The bit-error-rate (BER) is used as the

performance index for comparing different linear receivers of interest under various conditions.

The resulting system BER is compared with various interesting linear receivers in different channel environments. In what follows, the MMSE detection scheme is with perfect (or known) channel information, which is considered to be the optimal solution and benchmark for comparison. Moreover, it is noted that in [9] the inherent ambiguity problem was ignored when the Capon channel estimation was applied. That is, it assumed that the true initial weight of channel vector is known to consistent with the situation used in [9] for scaling $\hat{\mathbf{h}}(t)$. As in [10], we also derived the so-called MV-GSC-RLS algorithm under new transceiver model for the ST-BC MIMO CDMA receiver, which is an adaptive implementation of the LCMV-based blind Capon-type receiver. For comparison, the BER of the proposed algorithm and MV-GSC-RLS algorithm are computed by ignoring the first 500 iterations that are used in estimating the $\mathbf{R}_{yy}(t)$ for the blind Capon receiver and ensured the proposed algorithm converge.

First, we would like to examine the performance without mismatch effect. Here, QPSK modulation is adopted. The channel coefficients are assumed to be time-invariant with length $L = 3$, and are randomly generated, following a complex-Gaussian distribution with zero-mean and variance L^{-1} . The length of redundancy symbols is $D = 3$. The curves of SINR are plotted for 2000 iterations and generated with SNR=14 dB. First, we consider the case without mismatch; the curves of BER performance are given in Fig. 3. From Fig. 3, we found that the proposed scheme is superior to the blind Capon receiver and MV-GSC-RLS algorithm. Similar results for the case with mismatch are shown in Fig. 4, for reference. Also, the channel estimation per a pair of block signals with the power method together with channel information extracted from the hybrid AUS vector in the receiver required less iteration to converge. This is revealed from Fig. 5 and Fig. 6.

IV. CONCLUSIONS

In this paper, we proposed new transceiver for the ST-BC MIMO-CDMA systems to resolve the phase ambiguity and remove partial effects of ISI, MAI, and SI. With specific design of the hybrid augmented signature code-sequences of desired user in the transmitter, the phase ambiguity problem of Capon blind receiver could be resolved together with power method. Also, in the receiver, we proposed the Capon-like adaptive blind MIMO-CDMA detector with two-branch filterbank, implemented by the proposed GSC-CM-RLS algorithm, to combat the above-mentioned problems. With this new transceiver framework we could achieve performance improvement and resolving the phase ambiguity problem, simultaneously. As verified in the computer simulation results, the new proposed hybrid signature code-sequences MIMO-CDMA receiver, with the CM-GSC-RLS algorithm, outperformed the conventional Capon receiver proposed in [9], with known true channel information, and the one with the

MV-GSC-RLS (with the LCMV criterion), in terms of BER. This is especially true for the mismatch case.

ACKNOWLEDGMENT

The financial support of the National Science Council, Taiwan, R.O.C., under contract NSC 102-2221-E-032 -007 is of great acknowledged.

REFERENCES

[1] Z. Liu, G. B. Giannakis, B. Muquet, and S. Zhou, "Space-time Coding for Broadband Wireless Communications," *Wireless Commun. Mobile Comput.*, vol. 1, no. 1, Jan.-Mar. 2001, pp. 35-53.

[2] A. F. Naguib, N. Seshadri, and A. R. Calderbank, "Increasing Data Rate over Wireless Channels," *IEEE Signal Processing Mag.*, vol. 17, no. 3, May 2000, pp. 76-92.

[3] A. Jalali and P. Mermelstein, "Effects of Diversity, Power Control, and Bandwidth on the Capacity of Microcellular CDMA Systems," *IEEE Journal on Selected Areas in Communications*, vol. 12, no. 5, Jun. 1994, pp. 952-961.

[4] G. J. Foschini and M. J. Gans, "On Limits of Wireless Communication in a Fading Environment When Using Multiple Antennas," *Wireless Personal Communications*, vol. 6, no. 3, Mar. 1998, pp. 311-335.

[5] S. M. Alamouti, "A Simple Transmit Diversity Techniques for Wireless Communications," *IEEE J. Select. Areas Commun.*, vol. 16, no. 8, Oct. 1998, pp. 1451-1458.

[6] A. Naveed, M.A.S. Choudhry, I.M. Qureshi and T.A. Cheema "On Phase Ambiguity Of Real Channels: Blind Channel Equalization Using Second Order Statistics" *IEEE ICASST*, Sept. 2006, pp. 65 - 67

[7] G. N. Karystinos and D. A. Pados, "Supervised Phase Correction of Blind Space-Time DS-CDMA Channel Estimates" *IEEE Trans. Comm.*, vol.55, March. 2007, pp. 584-592.

[8] B. L. Hughes, "Differential Space-time Modulation," *IEEE Trans. Inform. Theory*, vol. 46, no. 7, Nov. 2000, pp. 2567-2578.

[9] H. Li, X. Lu, and G. B. Giannakis, "Capon Multiuser Receiver for CDMA Systems with Space-time Coding," *IEEE Trans. Signal Processing*, vol. 50, no. 5, May 2002, pp. 1193-1204.

[10] S. J. Chern, and M.-K. Cheng, "New ST-BC MIMO-CDMA Transceiver with Augmented User Signatures", *IEEE International Symposium on Intelligent Signal Processing and Communication Systems*, Dec. 06- 08, 2010, pp. 133-1365.

[11] H. Li, X. Lu, and G. B. Giannakis, "Capon Multiuser Receiver For CDMA Systems with Space-time Coding," *IEEE Trans. Signal Processing*, vol. 50, no. 5, May 2002, pp. 1193-1204.

[12] S. Y. Li, S. McLaughlin, X. Wei and D.G.M. Cruickshank, "Channel estimation and interference cancellation in CP-CDMA systems", *Communications, IET*, vol. 1, Feb. 2007, pp.106-112.

[13] F. Horlin, A. Bourdoux, E. Lopez-Estraviz, and L. V. der Perre, "Single-Carrier FDMA or Cyclic-Prefix CDMA with Optimized Spreading Sequences? ", *IEEE Transactions on Vehicular Technology*, vol. 57., Sep. 2008, pp. 3230-3234.

[14] Y.-S. Chen, and C.-A. Lin, "Blind Channel Identification for MIMO Single Carrier Zero Padding Block Transmission Systems", *Circuits and Systems I: Regular Papers, IEEE Transactions on*, vol. 55, July 2008, pp.1571-1579.

[15] S. Haykin, *Adaptive Filter Theory*, 4th ed. Upper Saddle River, NJ: Prentice-Hall, 2002.

[16] S. J. Chern and P.-S. Chao "New Capon-like Blind MIMO-CDMA Receiver with LCCM-RLS Algorithm for Multipath Time-varying Channels," *IEEE ISAPCS*, 8-11, Dec. 2008.

[17] J. Miquez and L. Castedo, "A Linearly Constrained Constant Modulus Approach to Blind Adaptive Multiuser Interference Suppression," *IEEE Commun. Lett.*, vol.2, no.8, Aug. 1998, pp.217-219.

[18] C. R. Johnson Jr., P. Schniter, T. J. Endres, J. D. Behm, D. R. Brown, and R. A. Casas, "Blind Equalization Using the Constant Modulus

Criterion: A Review," *Proc. IEEE*, vol. 86, no. 10, Oct. 1998, pp. 1927-1950.

[19] C. Xu and G. Feng, "Comments on: A Linearly Constrained Constant Modulus Approach to Blind Adaptive Multiuser Interference Suppression," *IEEE Commun. Lett.*, vol. 4, no. 9, Sep. 2000, pp. 280-282.

[20] J. P. de Villiers and L. P. Linde, "On the Convexity of the LCCM Cost Function for DS-CDMA Blind Multiuser Detection," *IEEE Commun. Lett.*, vol. 8, no. 6, Jun. 2004, pp. 351-353.

[21] C. Xu, G. Feng, and K. S. Kwak, "A Modified Constrained Constant Modulus Approach to Blind Adaptive Multiuser Detection," *IEEE Trans. Commun.*, vol. 49, no. 9, Sep. 2001, pp. 1642-1648.

[22] S. J. Chern and C. H. Sun, "Constrained Adaptive Constant Modulus RLS Algorithm for Blind DS-CDMA Multiuser Receiver Under Time-varying Channels," *IEICE Trans. Fundamentals*, vol. E90-A, no. 7, July 2007, pp. 1452-1461.

[23] E. Aktas and U. Mitra "Semiblind Channel Estimation For CDMA Systems" *IEEE Trans. Commun.*, vol. 52, July 2004, pp. 1102 - 1112.

[24] X. G. Doukopoulos, and G. V. Moustakides, "Adaptive Power Techniques for Blind Channel Estimation in CDMA Systems", *IEEE Transactions on Signal Processing*, vol. 53, no. 3, March 2005

[25] R. Sumit. and C. Li "A Subspace Blind Channel Estimation Method For OFDM Systems Without Cyclic Prefix" *IEEE trans. Wireless Commun.*, vol. 1, Oct. 2002, pp.572-579.

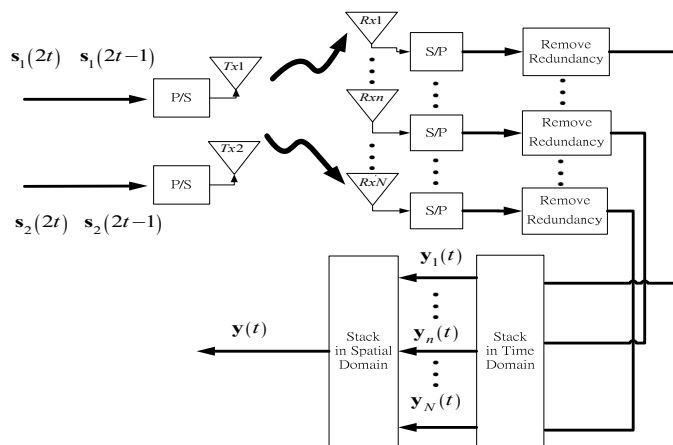

(a) Block diagram of the ST-BC MIMO-CDMA transceiver.

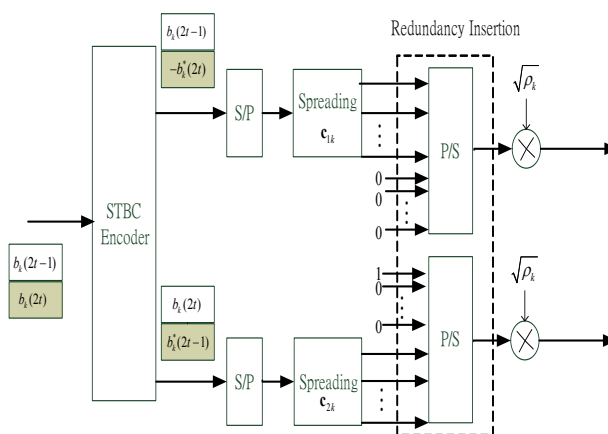

(b) The ST-BC CDMA configuration for k th user.

Fig. 1. Configuration of the ST-BC MIMO-CDMA systems

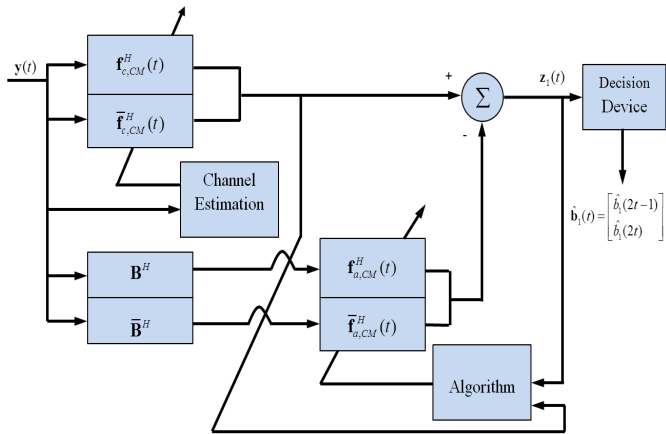

Fig. 2 Configuration of the MIMO CM-GSC-RLS algorithm

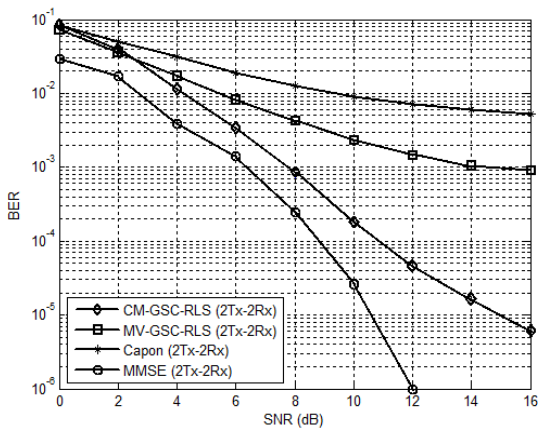

Fig. 3 BER comparison of different receivers without mismatch effect, for $L=3, N=2$.

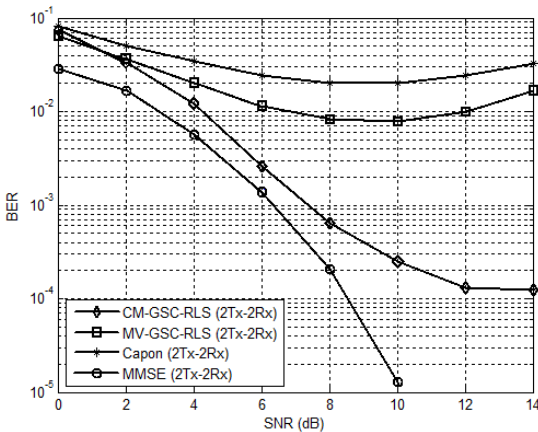

Fig. 4 BER comparison of different receivers with mismatch effect, for $L=3, N=2$.

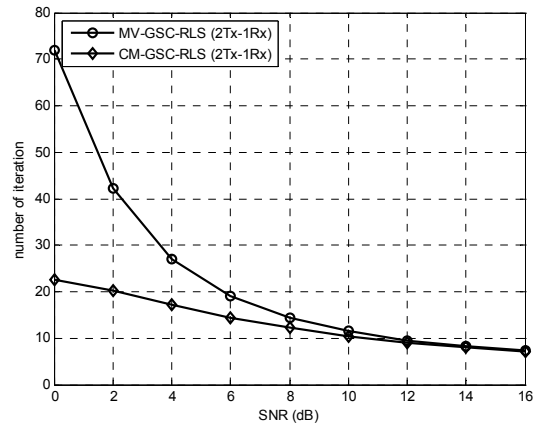

Fig. 5 The number of iteration with the initial vector all unity

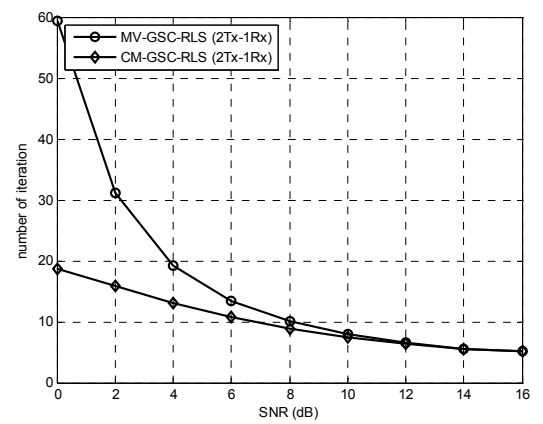

Fig. 6 The number of iteration with the initial vector to be with our estimated channel vector.